



Neon
Controls

“Go Brighter. Go Neon.”

Series 85

Two stage cylinder regulator



Series 85, shown with optional packless diaphragm valve

Typical Applications

- Laboratory and Point-of-Use Gas systems in medical, pharmaceutical, food and beverage, and other high purity gas applications
- Process analyzer gases, metal fabrication, petrochemical, and specialty industrial gas cylinders

Features and Benefits

- Simple poppet and seat design for easy maintenance
- 10 micron filter element to protect the regulator seat
- 3 point sub-seat seal protects against leakage
- 2 year factory warranty

The Neon 85 Series is a compact, lightweight, high purity, dual stage, pressure reducing regulator for specialty, flammable, and industrial gasses or liquids. We offer a multitude of outlet pressure, seat material, and flow coefficient options. Our sensitive, long life, 316L stainless steel diaphragms insure gas purity and integrity.

We offer a wide variety of body materials, porting options, and connections to meet your specific needs, while minimizing the internal unswept volume of the regulator. Regulators can be supplied with options such as installed pressure gauges, valves, and CGA assemblies.

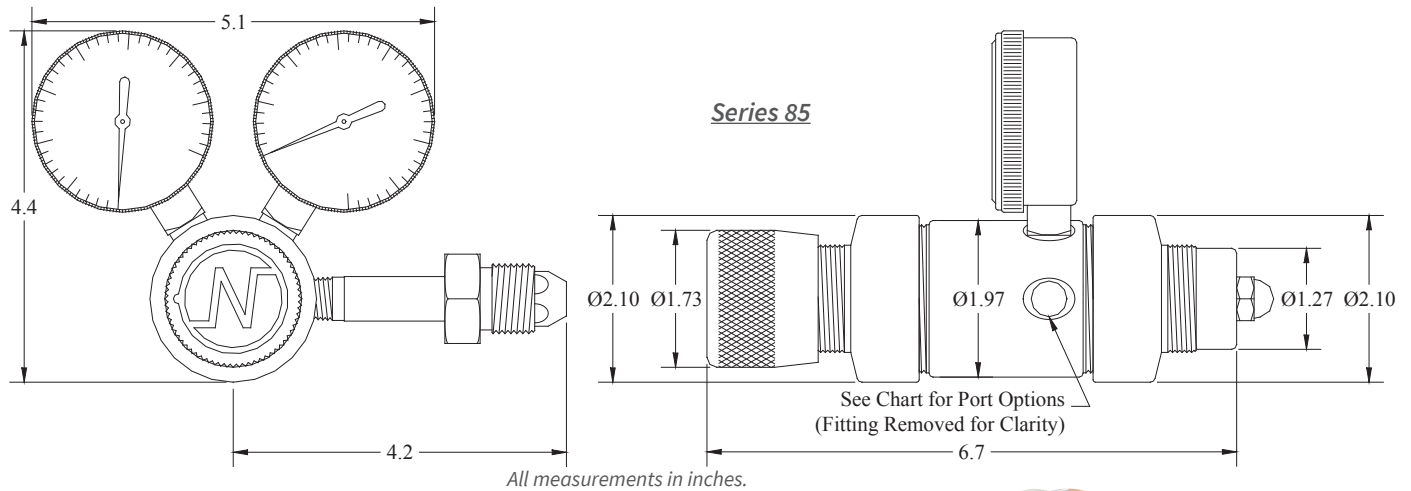

Specifications

For questions about this product, please contact Neon Controls.

Operating Parameters

Pressure rating per criteria of CGA E-4; ASME B31; ASME BPVC

Maximum Inlet Pressure

6000 psig / 415 Bar

Maximum Outlet Pressure

2, 10, 25, 50, 100, 250, 500, 750, 1000 psig

70, 175, 345, 690, 1725, 3450, 5170, 6895 kPa

1, 2, 3.5, 7, 17.5, 35, 52, 70 Bar

Design Proof Pressure

150% of rated pressure

Leakage

Internal: Bubble tight

External: Designed to meet $< 2 \times 10^{-8}$ atm/cc He

Operating Temperature

-40°F to 185°F / -40°C to 85°C

Flow Capacity

0.03, 0.07, 0.24, 0.3, 0.35, 0.58

Wetted Materials

Body

Brass, 316L Stainless Steel, Monel, Hastelloy C, Titanium, Electroless Nickel Plated Brass

Seat

Tefzel, Peek, PCTFE [standard], Vespel

Filter

10 micron 316L Stainless Steel

Seal

Teflon, Viton

Diaphragm

316L Stainless Steel with Tefzel Sealing Ring

Spring Housing

316L Stainless Steel, Electroless Nickel Plated Aluminum, Black Anodized Aluminum

Remaining Parts

Inconel

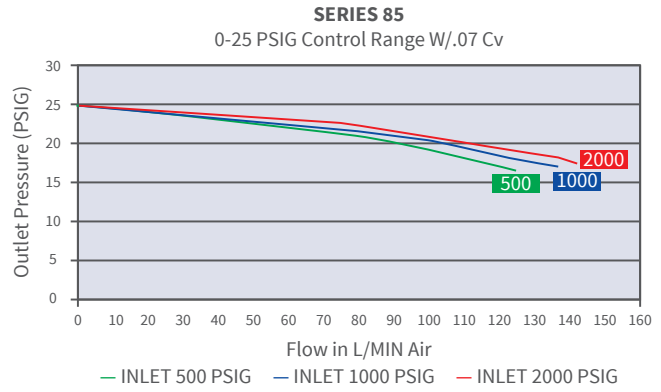
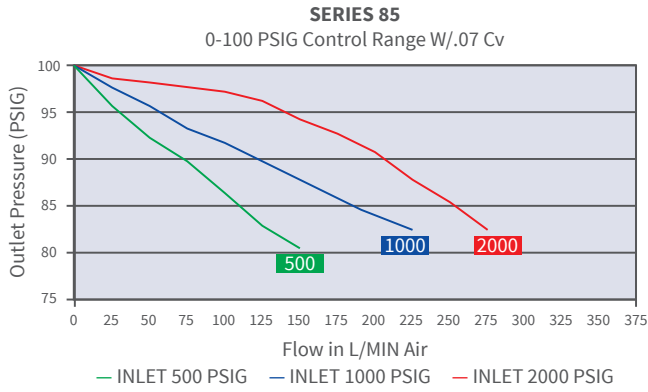

Series 85 - Stainless Steel

Standard Porting Configuration

(Chart A)

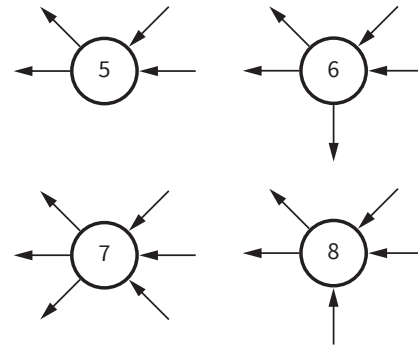

Many other porting configurations available

85	-	2	4	5	B	1
Series	-	Body Mtl	Outlet Range	Porting	Connection	Gauges
85		1 - Brass 2 - 316L SS 3 - Monel 4 - Hastelloy C 5 - Titanium 6 - Electroless Nickel Plated Brass	0 - 2 PSI 1 - 10 PSI 2 - 25 PSI 3 - 50 PSI 4 - 100 PSI 5 - 250 PSI 6 - 500 PSI 7 - 750 PSI 8 - 1000 PSI	See Chart A	A - 1/8" B - 1/4" C - 3/8" Others by request	1 - with gauges 2 - no gauges 3 - customer supplied

-	2	A	Z	C	-	2	A	Z	3	-	580
-	1st Stage: Cv	Diaphragm	Seat	Cap	-	2nd Stage: Cv	Diaphragm	Seat	Cap	-	CGA
	1 - 0.03 2 - 0.07 3 - 0.24 4 - 0.30 6 - 0.35 7 - 0.58	A - 316L SS w/Tefzel Ring B - 316LSS w/Teflon Shield	F - PCTFE [standard] K - Peek P - Vespel Z - Tefzel	A - ENP Al B - 316L SS C - Anod Al D - ENP Al PM E - 316L SS PM F - Anod Al PM With Acorn Nut		1 - 0.03 2 - 0.07 3 - 0.24 4 - 0.30 6 - 0.35 7 - 0.58	A - 316L SS w/Tefzel Ring B - 316LSS w/Teflon Shield	F - PCTFE [standard] K - Peek P - Vespel Z - Tefzel	1 - ENP Al 2 - 316L SS 3 - Anod Al 4 - ENP Al PM 5 - 316L SS PM 6 - Anod Al PM With Knob		Insert 3 digit portion of CGA number

Pressure and Temperature Rating for Seats				
Code	Material	Pressure in PSI Minimum	Pressure in PSI Maximum	Temperature Maximum
F	PCTFE	10	3600	150°F
Z	TEFZEL	10	2400	150°F
K	PEEK	50	6000	150°F
K	PEEK	50	3600	500°F
P	VESPEL	25	6000	150°F
P	VESPEL	25	3600	500°F

Special Options	
04	Relief Valve (<150 psi)
15	Outlet valve - packed
16	Outlet valve - packless
71	Find Adjust
73	Helium Leak Test
75	Relief Valve (150 psi +)
SR	Self-relieving (2 nd stage)

For other options contact factory

Shipping Weight: 5.5 pounds

How To Videos

Available 24/7

Smartphone & Tablet Compatible

<http://youtube.com/neoncontrols>



Warranty

Precision Instrumentation warrants each Neon regulator to be free from defects in materials and workmanship for two years after manufacture date.

In the unlikely event that a Neon regulator is defective in workmanship or materials, Precision Instrumentation will, at its discretion, repair or replace the regulator free of charge.

The selling distributor must process all warranty claims. If the original purchaser suspects a defect in a Neon regulator, the regulator, together with proof of purchase, must be returned to the selling distributor for evaluation and disposition.

This warranty applies only under conditions of use for which each regulator is designed and does not cover cosmetic damage or damage due to misuse, abuse, neglect, accident, improper installation, or acts of God. This warranty does not extend to or apply to any regulator that has been repaired or altered by any party other than Precision Instrumentation or its authorized distributors.

This warranty is in lieu of and excludes all other warranties, expressed or implied, including the warranties of merchantability and fitness for a particular purpose. Precision Instrumentation will not be liable for any special or consequential damages, or for any loss, damage or expense directly or indirectly arising from use of or inability to use any regulator, either separately or in combination with any other equipment or material, or from any other case.

Tefzel, Teflon & Vespel are registered trademarks of E.I. Dupont - Monel is a registered trademark of INCOAlloys Int.

Hastelloy is a registered trademark of Cabot Corp. KEL-F is a registered trademark of 3M.



Neon
Controls

“Go Brighter. Go Neon.”



Proudly made in the USA since 1988

13413 Benson Ave. | Chino, CA 91710 | 1-800-864-6810 | NeonControls.com

Neon Controls is a product of



Precision
Instrumentation

12/2014